

	Date:
	Client:
	Project:



**112**

One-handle build-in mixer with ceramic disc technology. 112UP = Mixer 100.112AP = Handle NR28, 160 mm fixed spout 010, two-hole plate 60 x 153 mm 3002.

**Flow**

	Bar:	1.0	2.0	3.0	4.0	5.0
112	(l/min)	2.9	4.1	5.0	5.0	5.0
112 <sup>1)</sup>	(l/min)	2.6	3.7	4.5	4.5	4.5

<sup>1)</sup> USA standard

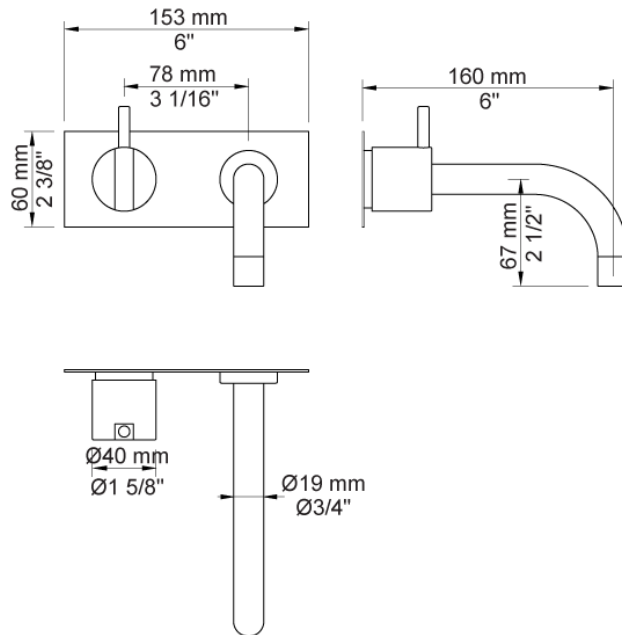

**Available in colors**

Color 02, Grey	Color 17, Gloss black
Color 04, Light blue	Color 18, White
Color 05, Orange	Color 19, Natural brass
Color 06, Light green	Color 20, Brushed chrome
Color 08, Yellow	Color 21, Carmine red
Color 09, Dark grey	Color 25, Pink
Color 12, Mocca	Color 27, Matt black
Color 14, Bright red	Color 28, Matt white
Color 15, Dark blue	Color 40, Brushed stainless steel
Color 16, Polished chrome	



**010**  
160 mm fixed spout with water saving aerator.

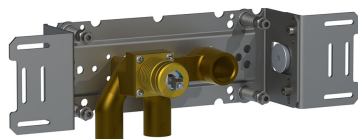
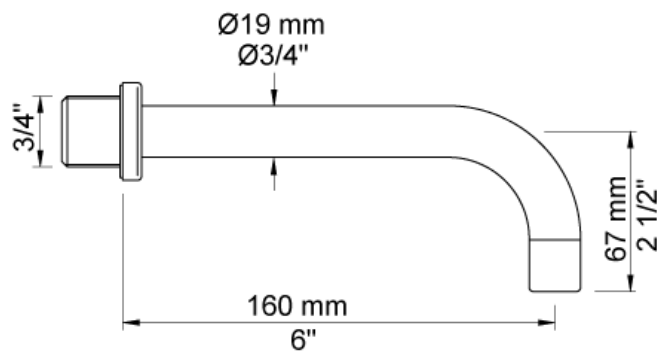

**100**  
One-handle build-in mixer with fixed outlet socket. 1/2" connection to copper, steel, iron or pex pipe work.

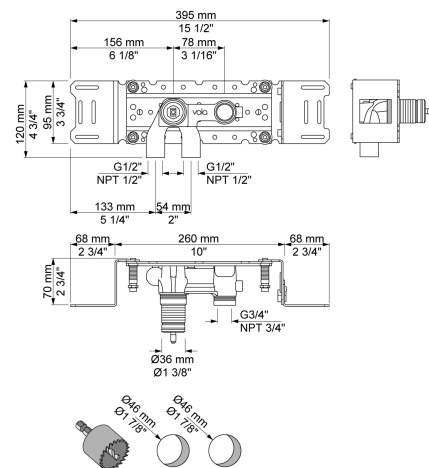

**3002**  
Two-hole plate, 60 x 153 mm. Holes Ø36 and Ø30 mm.

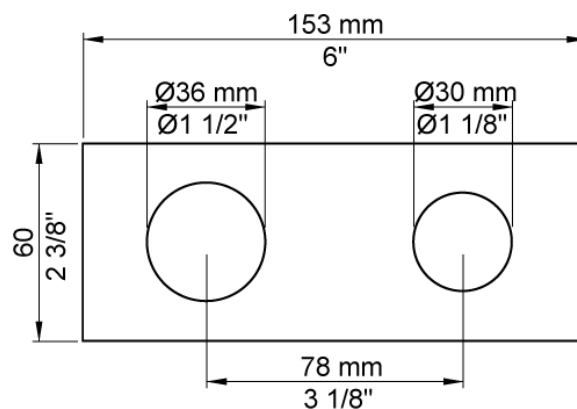



**NR28**  
Operating handle for 100, 200, 300, 400 incl. variants. Ø40 mm.

